

Right Angle Check Valves

These valves allow free flow in one direction and prevent flow in the reverse direction. Cracking pressure specified is the pressure required to open the valve and allow free flow.

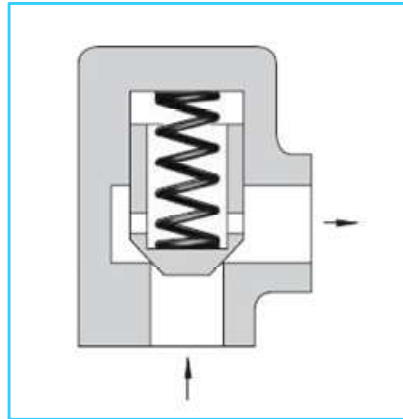

Graphic Symbol



Specifications

Model Numbers		Rated Flow * L/min	Max. Operating Press. Kgf/cm ²	Cracking Pres. Kgf/cm ²	Mass Kg
Sub-plate Mounting	CRG-03-※-50	40	250	0.4, 3.5, 5.0	1.7
	CRG-06-※-30	125		0.35, 2.0, 3.5, 5.0	4.1
	CRG-06-※-※-50H01			0.4, 3.5, 5.0	3.2
	CRG-10-※-50	250		0.4, 3.5, 5.0	5.5
Flanged Connection	CRF-16-※-50	600		0.4, 3.5, 5.0	15.6

* Rated flow is the approximate flow rate, when there is a free flow pressure drop of maximum 3 Kgf/cm², the fluid has a specific gravity of 0.85, a kinematic viscosity of 20cSt, and the cracking pressure is 0.4 Kgf/cm².

Model Number Designation

F-	CR	G	-03	-04	-T	-50	H01
Series Number	Type of Connection	Type of Connection	Valve Size	Cracking Pressure Kgf/cm ²	Type of Operation	Design Number	Design Standard
F: Special seals for phosphate ester type fluid (Omit if not required)	CR: Right Angle Check Valve	G: Sub-plate Mounting	03	0.4:0.4, 35:3.5, 50:5.0	None: Without hand knob	50	---
			06	5:0.35, 30:2.0, 50:3.5, 75:5.0		T: With Hand Knob	30
				10	04:0.4, 35:3.5, 50:5.0	50	H01
		F: Flanged Connection	16	04:0.4, 35:3.5, 50:5.0	None: Without hand knob	50	---

Mounting Bolts

Socket head cap screws in the table below are included.

Valve Model Numbers	Soc. head cap screw	Qty.	Mounting Bolt Ordering Code
CRG-03-※-50	M10 x 45 Lg.	4	BKCRG-03-50
CRG-06-※-30	M16 x 70 Lg.	4	BKCRG-06-30
CRG-06-※-50H01	M10 x 50 Lg.	4	BKCRG-06-50H01
CRG-10-※-50	M10 x 55 Lg.	6	BKCRG-10-50

Pipe Flange Kits

Pipe flange kits are available. When ordering, specify kits model from the table below.

Valve Model Numbers	Pipe Flange Kit Model Numbers	
	For Socket Welding	Threaded Connections
CRF-16	F3-16※-A-11	F3-16※-B-1180

● **CRG-03-※-50**

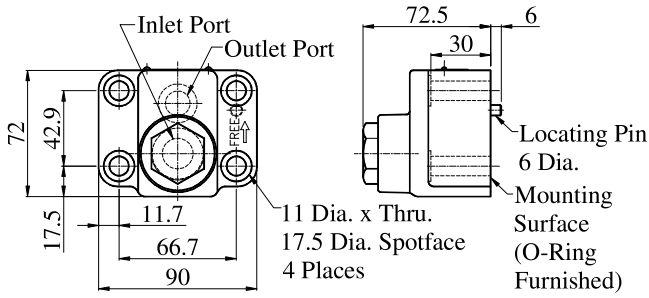

● **CRG-06-※-30**

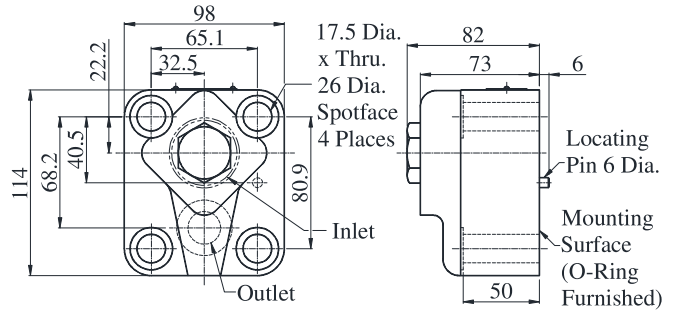

● **CRG-03-※-T-50**

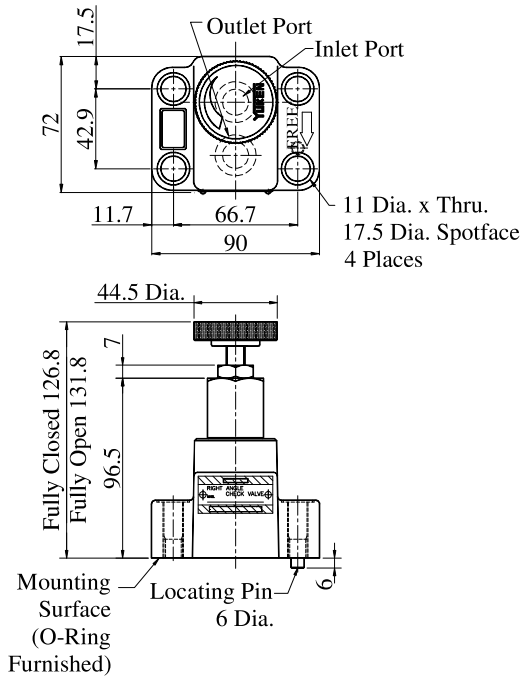

● **CRG-06-※-T-30**

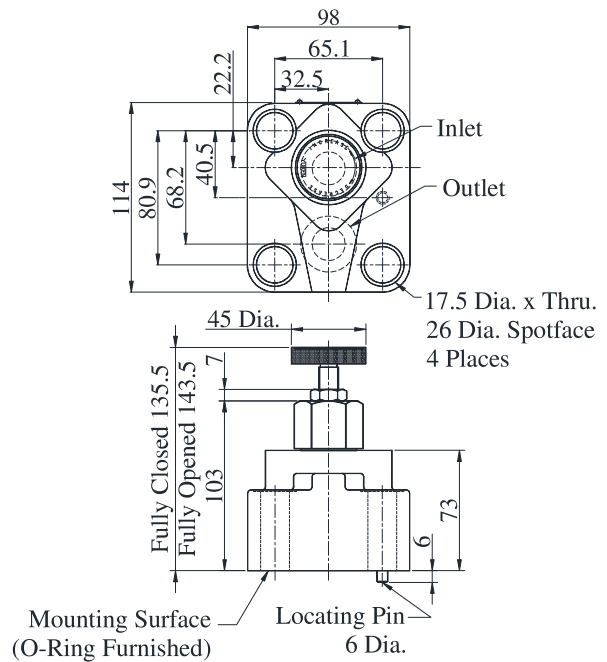

DIMENSIONS IN MILLIMETRES

● **CRG-06-※-50H01**

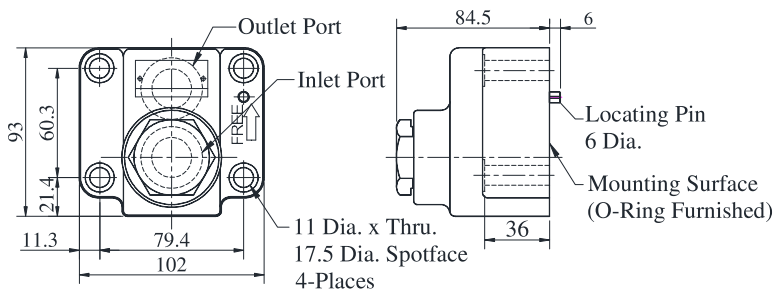

● **CRG-06-※-T-50H01**

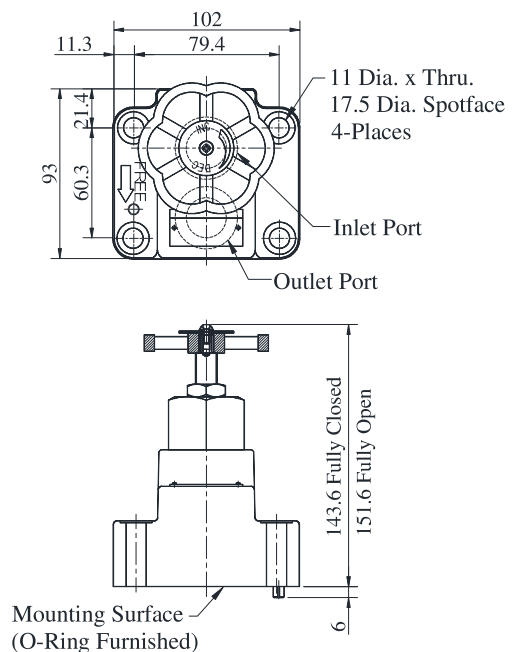

● **CRG-10-※-50**

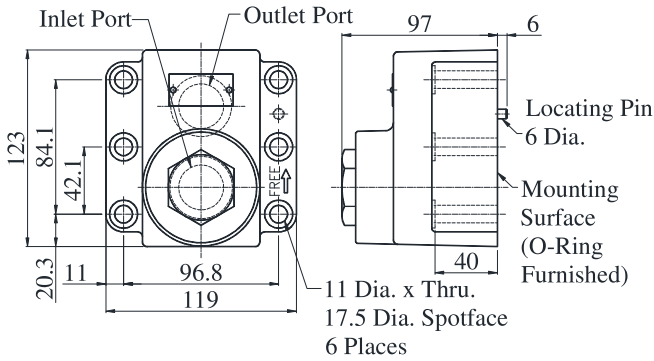

● **CRF-16-※-50**

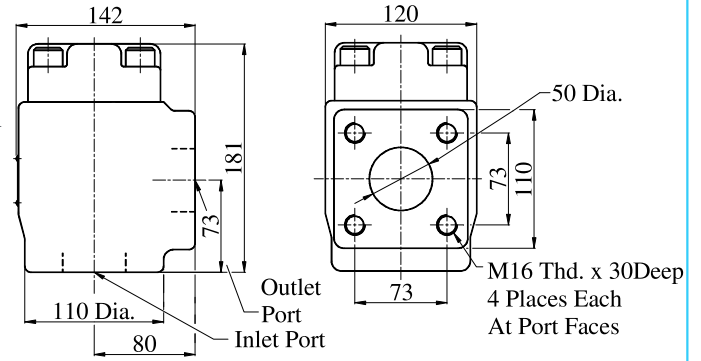

■ **Sub-plates**

Valve Model Number	Sub-plate Model Numbers	Thread Size	Mass (Approx.) Kg
CRG-03-※-50	CRGM-03-5080	3/8 BSP.F	1.6
	CRGM-03X-5080	1/2 BSP.F	1.6
CRG-06-※-30	CRGM-06-3080	3/4 BSP.F	3.2
	CRGM-06X-3080	1 BSP.F	3.0
CRG-06-※-50H01	CRGM-06-5080	3/4 BSP.F	3.2
	CRGM-06X-5080	1 BSP.F	3.0
CRG-10-※-50	CRGM-10-5080	1-1/4 BSP.F	4.8
	CRGM-10X-5080	1-1/2 BSP.F	5.7

Sub-plates are available. Specify sub-plate model from the table above. When sub-plates are not used, the mounting surface should have a good machined finished.

DIMENSIONS IN MILLIMETRES

● **CRGM-03-5080
03X**

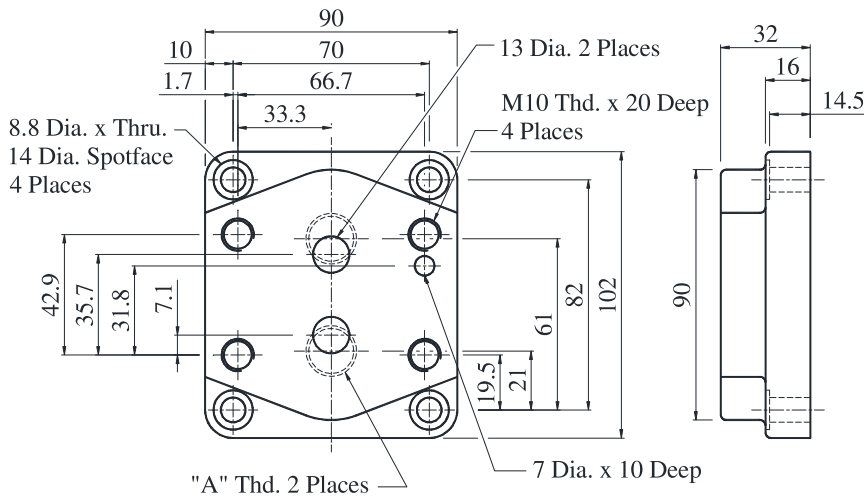

Sub-plate Model Numbers	"A" Thd.
CRGM-03-5080	3/8 BSP.F
CRGM-03X-5080	1/2 BSP.F

Right Angle Check Valves

● **CRGM-06-3080**

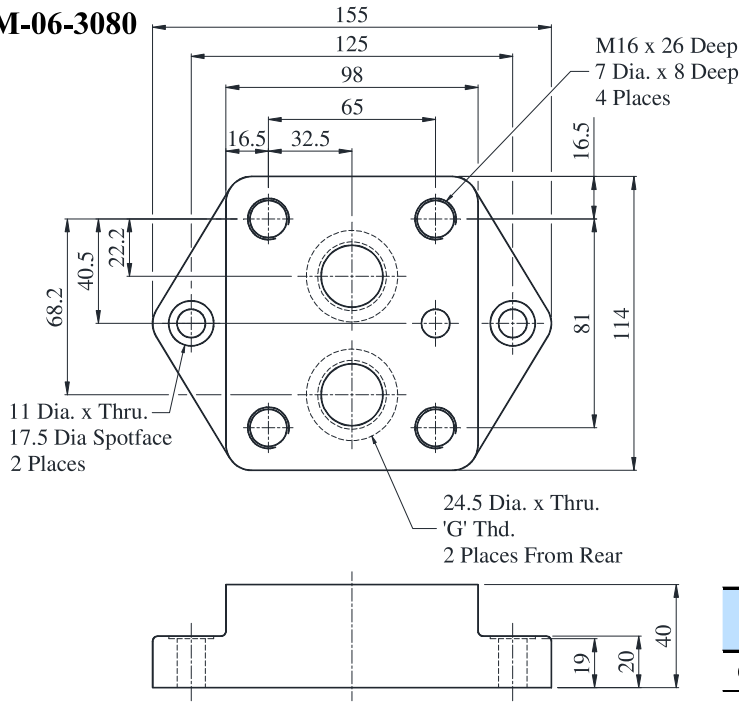

DIMENSIONS IN MILLIMETRES

Sub-plate Model Numbers	"A" Thd.
CRGM-06-3080/5080	3/8 BSP.F
CRGM-06X-3080/5080	1/2 BSP.F

● **CRGM-06-5080**

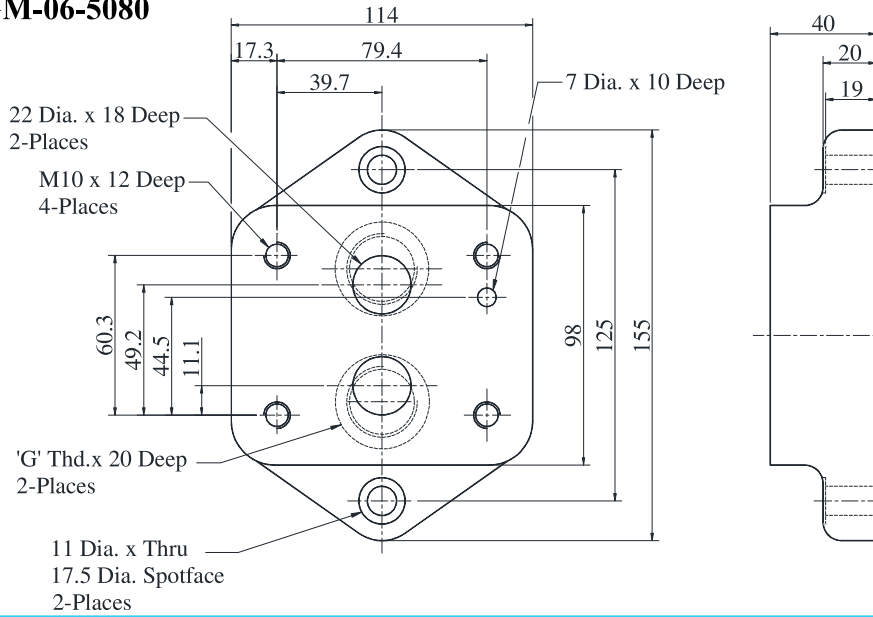

● **CRGM-10-10X-3080**

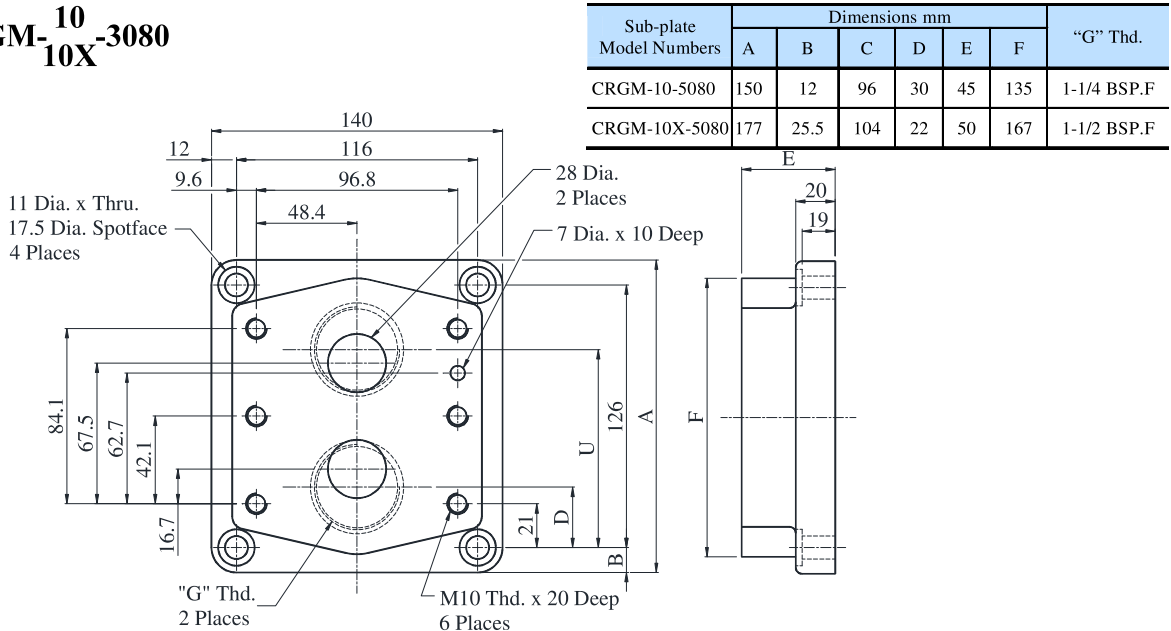

Sub-plate Model Numbers	Dimensions mm						"G" Thd.
	A	B	C	D	E	F	
CRGM-10-5080	150	12	96	30	45	135	1-1/4 BSP.F
CRGM-10X-5080	177	25.5	104	22	50	167	1-1/2 BSP.F

Right Angle Check Valves

Pressure Drop

● **CRG-03-※※-※-50**

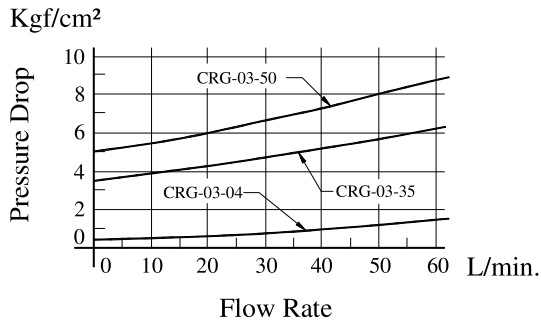

● **CRG-10-※※-※-50**

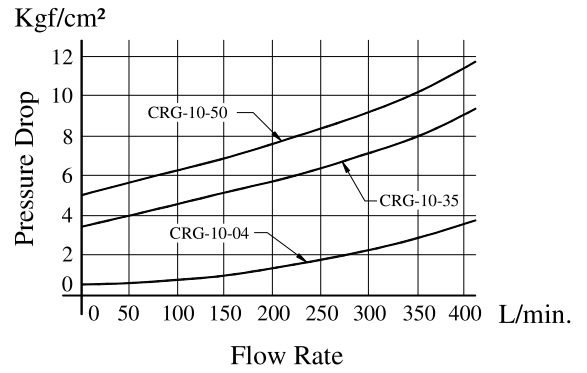

● **CRG-06-※※-※-30**

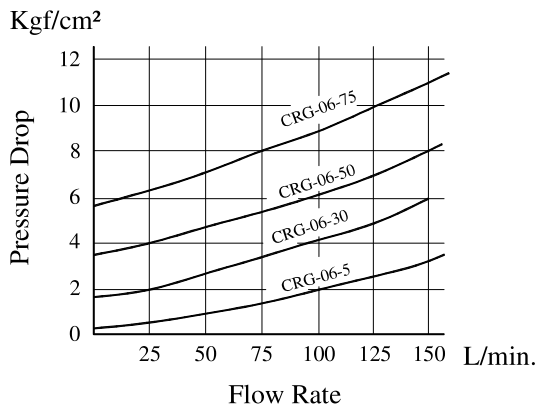

● **CRF-16-※※-※-50**

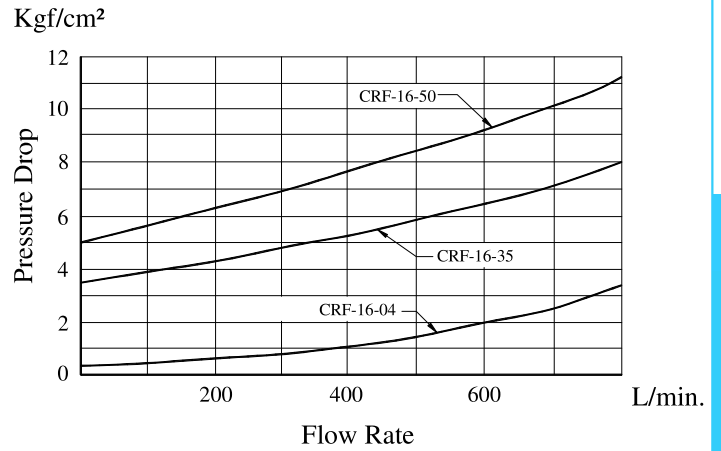

● **CRG-06-※※-※-50H01**

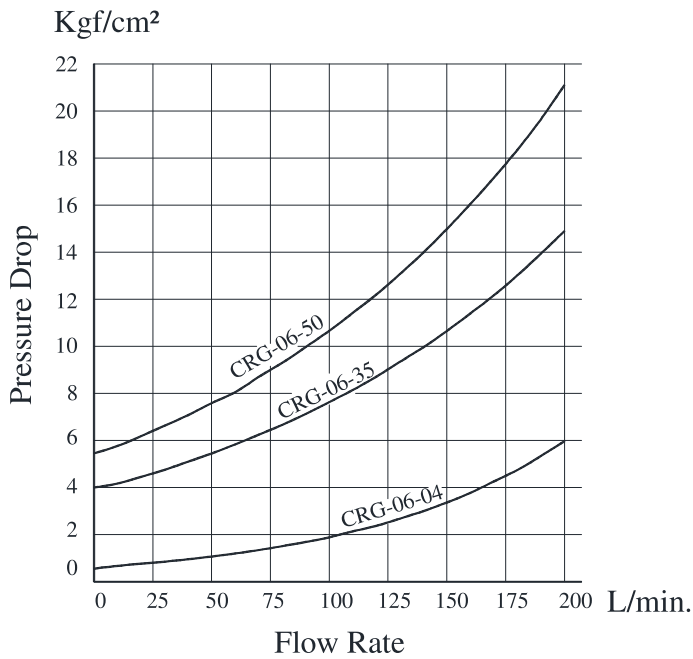

E
Right Angle Check Valves

Spare Parts List

● **List of Seals**

Sl. No.	Name of Part	Model No.							
		CRG-03	CRG-03-T	CRG-06	CRG-06-T	CRG-10	CRG-10-T	CRF-16	Qty.
1	O –Ring	--	SO-NA-P3	--	--			--	1
2	Backup Ring	--	SO-BB-P3	--	--			--	1
3	O –Ring	SO-NB-P21		--	--			--	1
4	O –Ring	SO-NB-P18		--	--			--	2
5	O –Ring	--	--	SO-NB-P24				--	1
6	O –Ring	--	--	SO-NB-P28				--	2
7	O –Ring	--	--	--	SO-NA-P5			--	1
8	Backup Ring	--	--	--	SO-BB-P5			--	1
9	O –Ring	--	--	--	--	SO-NB-P32		--	3
10	O –Ring	--	--	--	--	--	SO-NA-P7	--	1
11	Backup Ring	--	--	--	--	--	SO-BB-P7	--	1
12	O –Ring	--	--	--	--	--	--	SO-NB-G60	1

Note : When ordering the seals, please specify the seal kit number from the table as below.

● **List of Seals Kits**

Sl. No.	Model No.	Seal Kit No.
1	CRG-03-50	KS-CRG-03-50
2	CRG-03-T-50	KS-CRG-03-T-50
1	CRG-06-※	KS-CRG-06-30
2	CRG-06-T-※	KS-CRG-06-T-30

Sl. No.	Model No.	Seal Kit No.
1	CRG-10-50	KS-CRG-10-50
2	CRG-10-T-50	KS-CRG-10-T-50
1	CRF-16-50	KS-CRF-16-50