

● **RCG-03-※-2280**

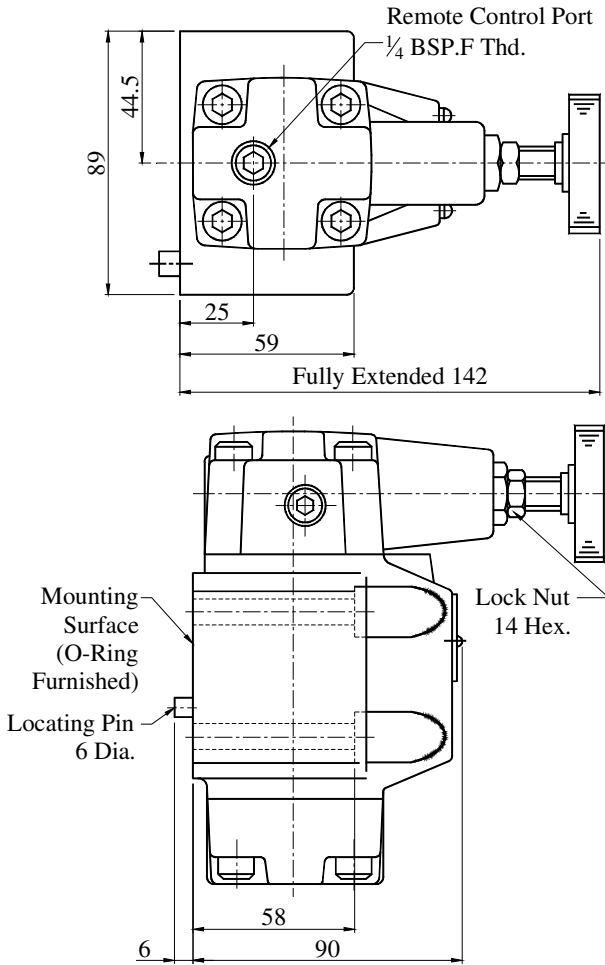

* Port connection is not required for RCG models but an O-Ring should be furnished.

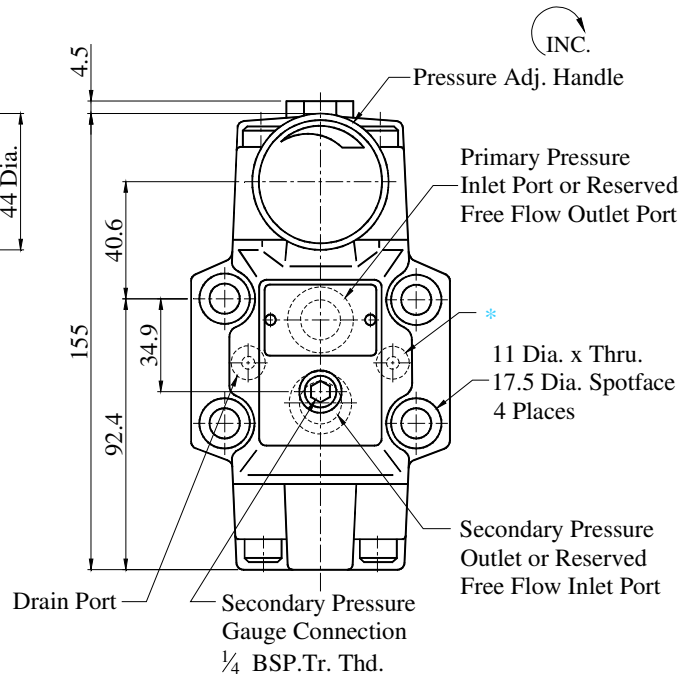

DIMENSIONS IN MILLIMETRES

● **RCG-06-※-2180**

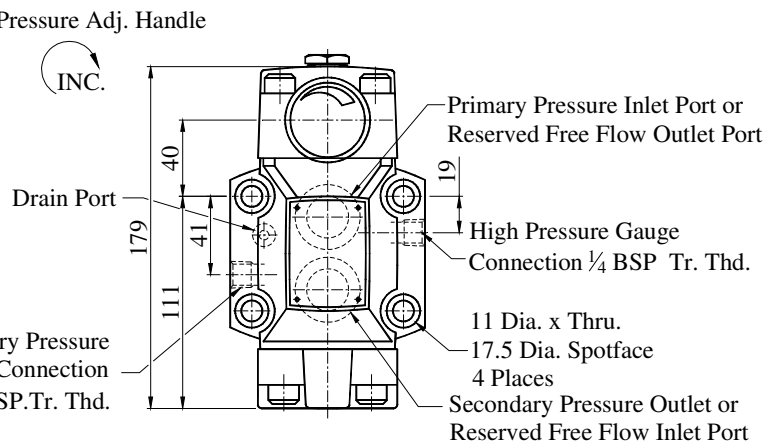
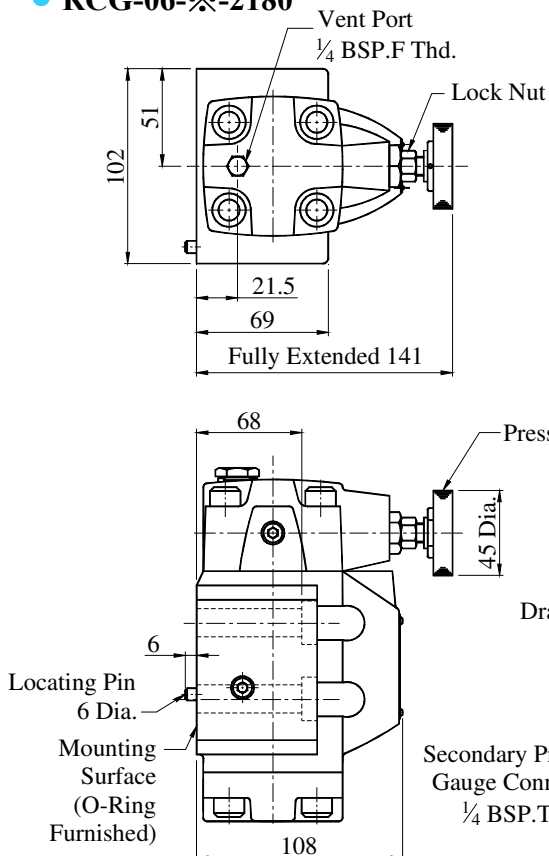

● **RCG-10-※-2180**

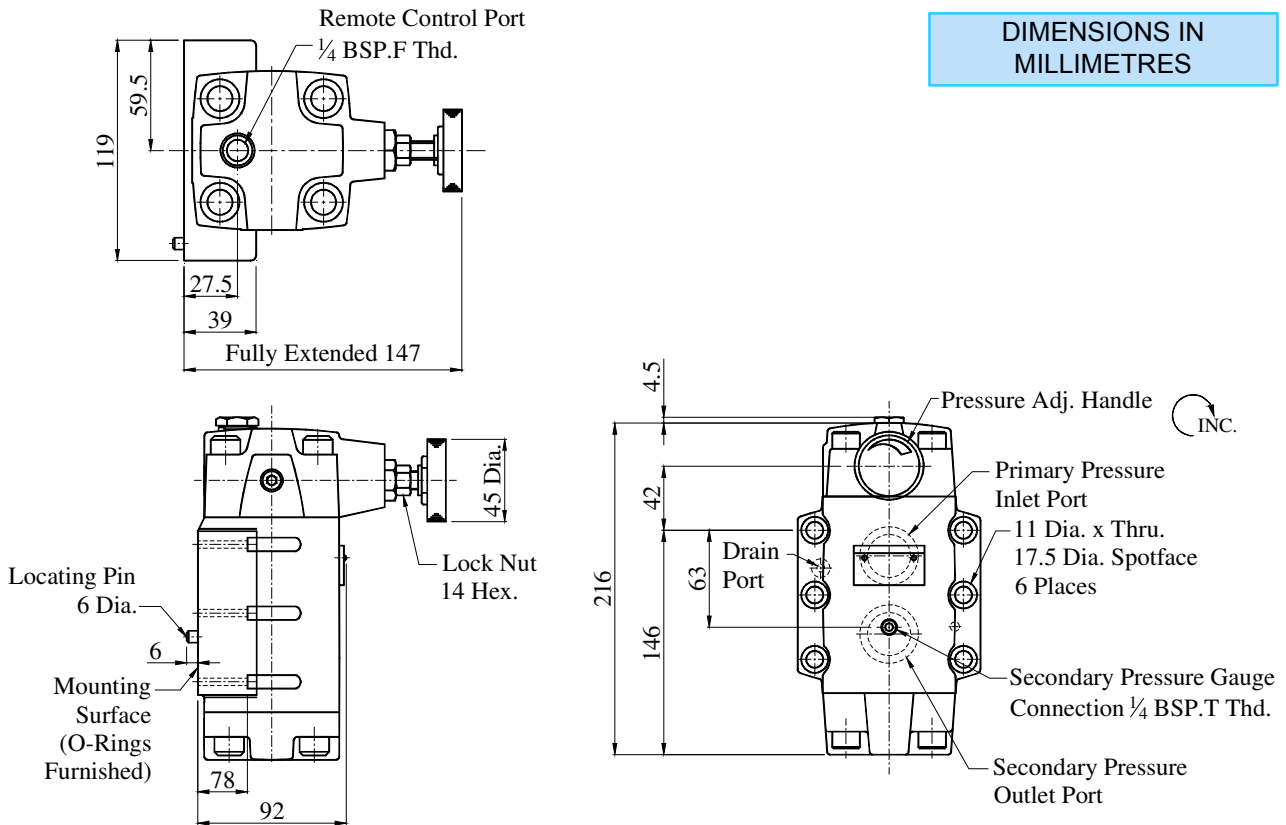

DIMENSIONS IN MILLIMETRES

■ **Spare Parts List**

● **List of Seals**

Sl. No.	Name of Parts	Part Numbers			Quantity			
		RCT RCG -03	RCT RCG -06	RCT RCG -10	RCT-※	RCG-※	RCG-06	RCG-10
1	O - Ring	SO-NB-P6	SO-NB-P6	SO-NB-P6	4	4	4	4
2	O - Ring	SO-NA-P9	SO-NA-P9	SO-NA-P9	1	1	1	1
3	O - Ring	SO-NB-P9	SO-NB-P9	SO-NB-P9	-	2	2	1
4	O - Ring	SO-NB-P12	SO-NB-P18	SO-NB-P22A	1	1	1	1
5	O - Ring	SO-NB-P18	SO-NB-P28	SO-NB-P32	-	2	2	2
6	O - Ring	SO-NB-P22		SO-NB-P36	2	2		2
7	O - Ring	-	SO-NB-G30	-	-	-	2	-
8	Bonded Seal	SG-FB-1/4	SG-FB-1/4	SG-FB-1/4	1	1	1	1

Note: When ordering the seals, please specify the seal kit number from the table below.

● **List of Seals Kits**

Valve Model Numbers	Seal Kit Numbers
RCT-03-※-2280	KS-RCT-03-22
RCT-06-※-2280	KS-RCT-06-22
RCT-10-※-2280	KS-RCT-10-22
RCG-03-※-2280	KS-RCG-03-22
RCG-06-※-2180	KS-RCG-06-21
RCG-10-※-2180	KS-RCG-10-21